

H014 - Honda CBR 1000 RR Fireblade SP/SP2 '17/'17 - pedana lato cambio

H014 - Honda CBR 1000 RR Fireblade SP/SP2 '17/'17 - rearset gear side

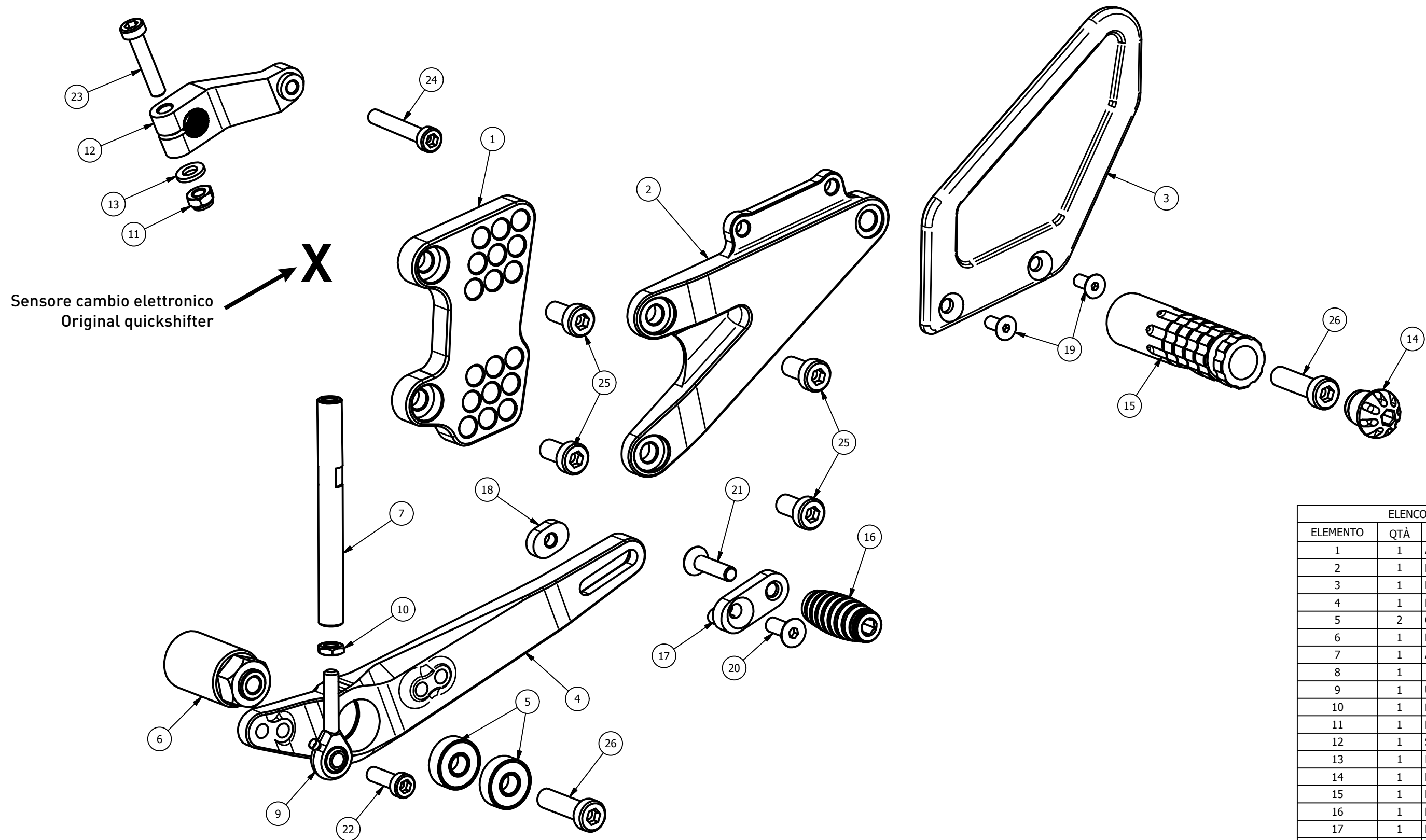

ELENCO PARTI		
ELEMENTO	QTÀ	NUMERO PARTE
1	1	AR_117
2	1	PS_059
3	1	BT_024
4	1	LC_038
5	2	CS_003
6	1	DC_032
7	1	AC_004 - 100mm
8	1	
9	1	Uniball maschio DX
10	1	Dado M6 DX
11	1	Dado autobloccante M6
12	1	SC_002B - alto M7
13	1	Rondella ø6mm
14	1	PG_00
15	1	PG_04 - 82mm
16	1	PU_001
17	1	PU_004
18	1	PU_005
19	2	M5x12 T.S. - 8.48 Nm*
20	1	M6x16 T.S. - 14.71 Nm*
21	1	M6x25 T.S. - 14.71 Nm*
22	1	M6x20 TCEI - 10.30 Nm*
23	1	M6x30 TCEI - 10.30 Nm*
24	1	Original screw
25	4	M8x16 TCEI - 25.50 Nm*
26	2	M8x30 TCEI - 25.50 Nm*



Attention: check the tightening of the screws before using - Components for racing use only  
 Attenzione: controllare il serraggio delle viti prima dell'uso - Componenti solo per uso agonistico

\*tightening torque - \*coppia di serraggio